

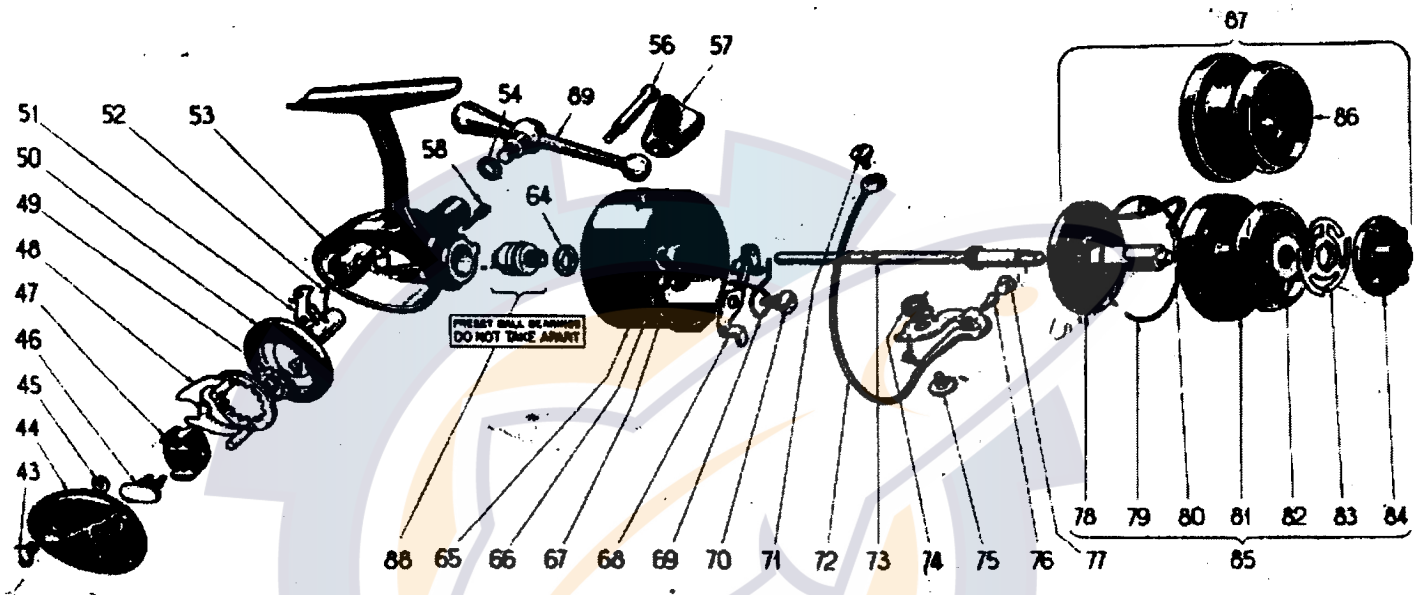

308 1960  
309 1961

# MITCHELL 308-309

## PARTS LIST

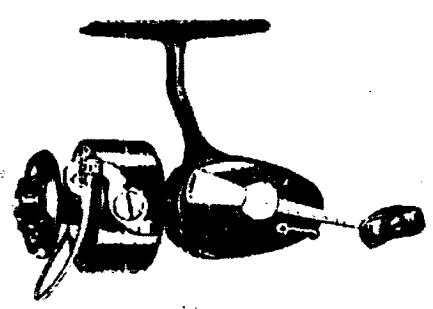

No.	Nomenclature	Price
43	Cover Lock Screw	.15
44	Cover Plate	.75
44 L	Cover Plate--Left Hand Reel	.75
45	"C" Lock	.10
46	Slide Lock	.25
47	Slide	1.00
48	Cam Ring Assembly	1.00
49	Planomatic gear and transfer slide	.50
50	Drive Gear	2.50
50 L	Drive Gear--Left Hand Reel	2.50
51	Anti Reverse Dog	.15
52	Anti Reverse Spring	.10
52 L	Anti Reverse Spring--Left Hand Reel	.10
53	Housing	5.50
53 L	Housing--Left Hand Reel	5.50
54	Handle Spacer	.05
56	Handle Knob Screw	.05
57	Handle Knob	.25
57 L	Handle Knob--Left Hand Reel	.25
58	Pinion Gear Assembly Set Screw	.15
64	"D" Spacer	.05
65	Rotating Head	3.00
65 L	Rotating Head--Left Hand Reel	3.00
66	Lock Nut Washer	.05
67	Lock Nut	.15
68	Trip Lever	.50
68 L	Trip Lever--Left Hand Reel	.50

No.	Nomenclature	Price
69	Trip Lever Spring	.10
69 L	Trip Lever Spring--Left Hand Reel	.10
70	Trip Lever Screw	.05
71	Bail Screw #2	.15
72	Bail	2.95
72 L	Bail--Left Hand Reel	2.95
73	Reel Axle	1.00
74	Bail Spring	.10
74 L	Bail Spring--Left Hand Reel	.10
75	Bail Screw #1	.15
76	Friction Guide	1.25
77	Friction Guide Screw	.05
78	Spool Spindle	.75
79	Spool Line Clip	.05
80	Click Spring	.25
81	Spool Shell (Large Capacity)	2.50
82	Fibre Washer (Large Capacity Spool Only)	.05
83	Brake Spring	.25
84	Wing Nut	.15
85	Complete Spool (Large Capacity)	4.00
86	Spool Shell (Small Capacity)	2.50
87	Complete Spool (Small Capacity)	4.00
88	Pinion Gear and Ball Bearing Assembly--DO NOT TAKE APART	3.75
89	Handle Complete	1.25
89 L	Handle Complete--Left Hand Reel	1.25

